



FORGED STAINLESS STEEL CHECK VALVES - ANSI CLASS 150 ~ 800

DESIGN DESCRIPTION:

- BOLTED COVER
- LIFT TYPE

APPLICABLE STANDARDS:

- DESIGN PER API 602
- SOCKET WELD AND THREADED END PER ANSI B16.11
- PIPE THREADS PER ANSI B1.20.1
- FLANGED END PER ANSI B16.5
- INSPECTION AND TEST PER API 598

SOCKET WELD ENDS SCREWED ENDS FLANGED ENDS

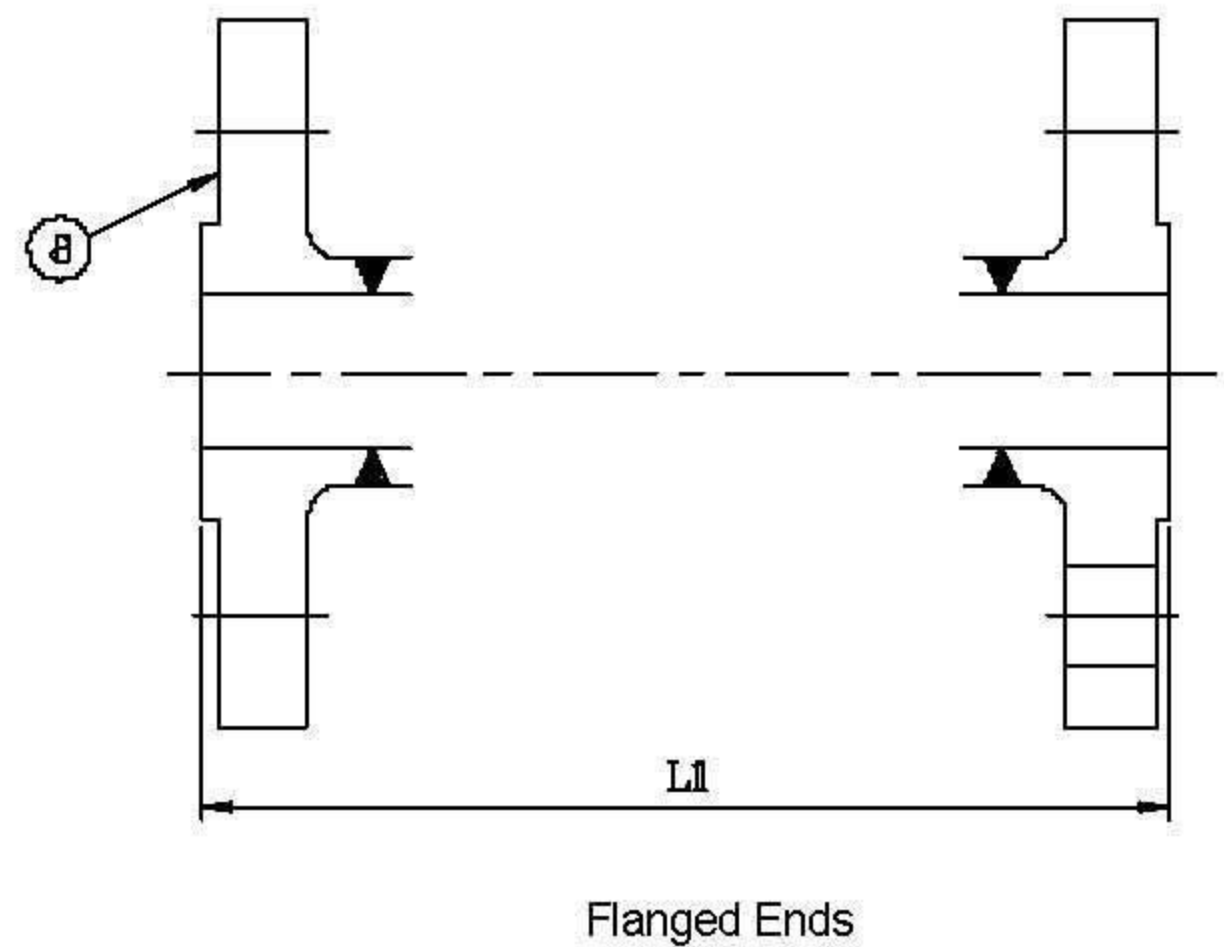
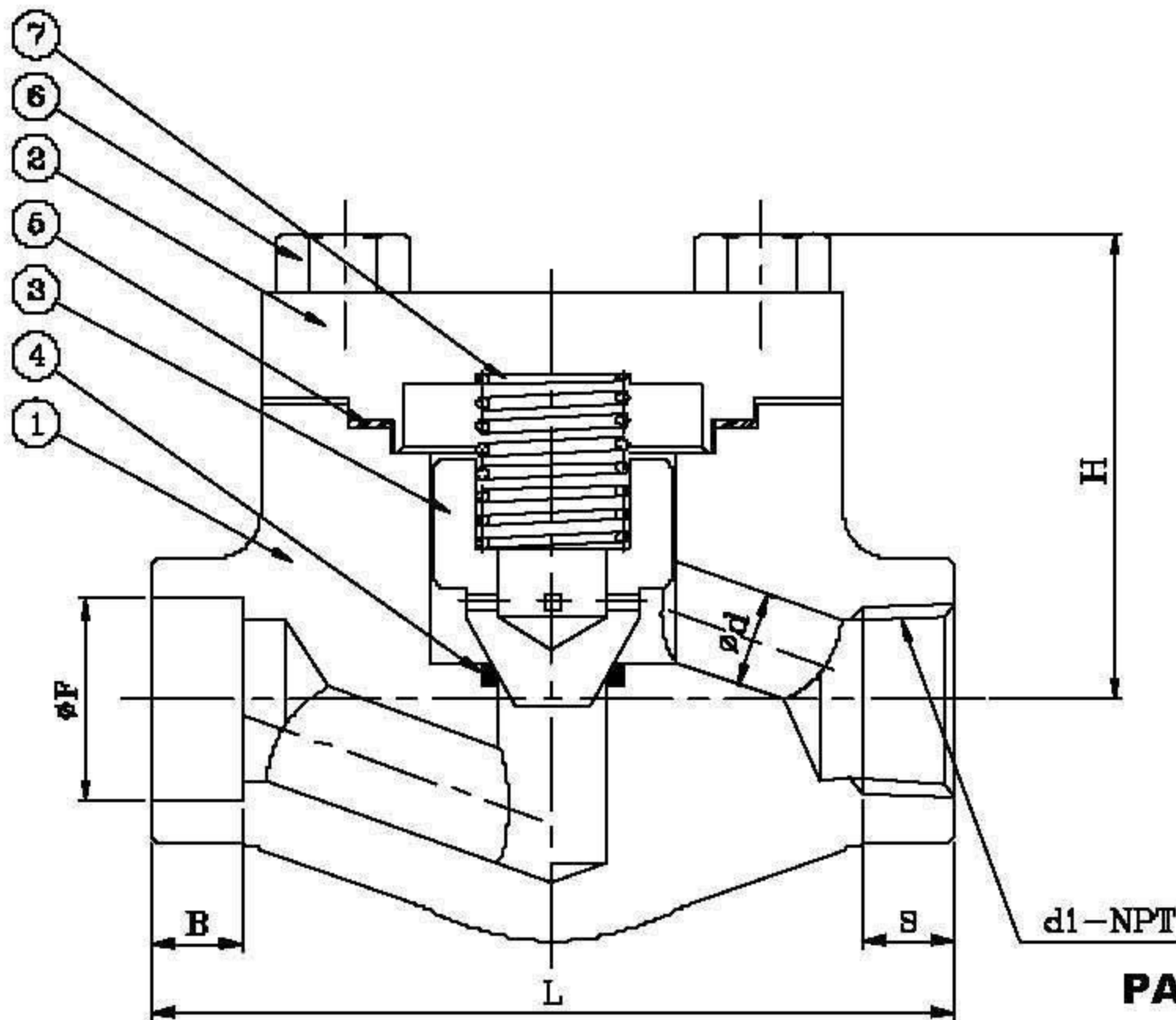

TEST PRESSURE TO API 598

CLASS	SHELL TEST (water)	SEAT TEST (water)	PSIG	
			SEAT TEST (water)	SEAT TEST (air)
150	450 (32 kg/cm ²)	314 (22 kg/cm ²)	80 (6 kg/cm ²)	80 (6 kg/cm ²)
300	1125 (79 kg/cm ²)	814 (57 kg/cm ²)	80 (6 kg/cm ²)	80 (6 kg/cm ²)
600	2225 (156 kg/cm ²)	1628 (114 kg/cm ²)	80 (6 kg/cm ²)	80 (6 kg/cm ²)
800	3000 (210 kg/cm ²)	2200 (154 kg/cm ²)	80 (6 kg/cm ²)	80 (6 kg/cm ²)

PARTS AND MATERIAL (ASTM)

NO.	PARTS NAME	MATERIALS	
		A182-F304	A182-F316
1	Body	A182-F304	A182-F316
2	Cover	A182-F304	A182-F316
3	Disc	A276-304	A276-316
4	Seat	A276-304+HVF STL#6	A276-316+HVF STL#6
5	Gasket	Grafoil + 304 Spiralwound	Grafoil + 316 Spiralwound
6	Cover Bolt	A193-B8	A193-B8
7	Spring	SUS 304	SUS 316
8	Flange	A182-F304	A182-F316

OTHER MATERIALS ARE AVAILABLE UPON REQUEST.

DIMENSION TABLE:

DN	NPS	Ø d	L	L1			H	SOCKET WELD		SCREWED		WT.(Kg) SW/ NPT
				150#	300#	600#		ØF	B	d1	S	
15	1/2	10	79	108	152	165	48	22	10	1/2" NPT	13.5	1.3
20	3/4	14	92	118	178	191	48	27	13	3/4" NPT	14.0	1.6
25	1	18	111	127	203	216	63	34	13	1" NPT	17.5	2.9
40	1 1/2	28	152	165	229	241	85	49	13	1 1/2"	18.5	6
50	2	34	172	203	267	292	104	61	16	2" NPT	19.0	9.7